

Panel-mounted Selector Switches

Type IC5846

Specification	MIL-C-2212
Application	Where ever maintained contact switching of control circuits is required.
Positions	Two or three position switches are available.



Selector Switch

Outline and Mounting Dimensions (In Inches)

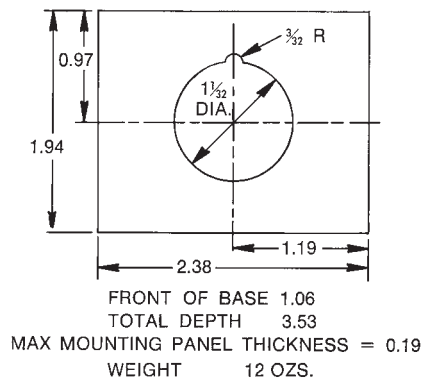

WIRING SYMBOLS

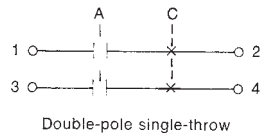

Position Location Front View

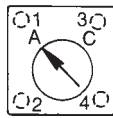
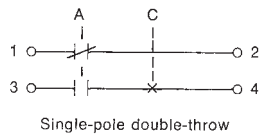
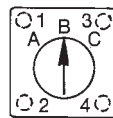
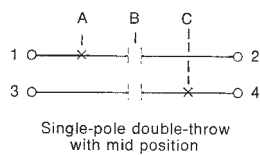
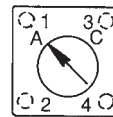

All contacts are maintained

Contact Ratings (Amperes)

Volts	Carry Continuous	Interrupt
115 VAC	10	3.0
440 VAC	10	0.5
115 VDC	10	1.0
230 VDC	10	0.3

Contact Arrangement Catalog Number

Contact Arrangement	Catalog Number
Double-pole single-throw	5729122G1
Single-pole double-throw with mid position	5729122G2
Single-pole double throw	5729122G3

Ordering Information

Order selector by catalog number. Nameplate, if required, must be ordered separately. Order standard nameplate by catalog number. Specify marking for special nameplate.

Panel-mounted Selector Switches

Type IC5846

Standard Selector-switch Nameplates

Nameplate Marking	Catalog Number
Stop – Start	NP93396C
Off – On	NP93396A
Stop – Run	NP94647B
Auto – Hand	NP94647D
Manual – Auto	NP97168A
Local – Remote	NP97168B
Off – Auto	NP97261C
Low – High	NP99265B
Man – Off – Auto	NP145872B
Hand – Off – Auto	NP97261D
Low – Off – Auto	NP97261B
Run – Off – Auto	NP145872A
On – Off – Remote	NP110849A
Blank	NP161895A
Special Nameplate Marking	-

Outline and Mounting Dimensions (In Inches)

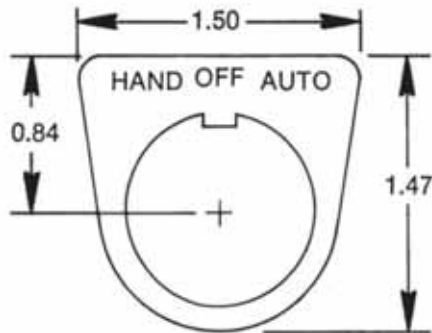

Nameplate

Rotary and Momentary Selector Switches

Styles JF and JFM

Silver to Silver Contacts

- Silver overlay on bronze
- Low contact resistance
- Self-wiping actions
- Non-shorting - break before make
- Solder connections

Dust Proof Mounting

- "V" ring construction on shaft and mounting bushing
- Non-turn device included
- Single hole mounting for 1" - 24 thread

Kel-F Sections

- Unitized construction
- Available in one to five sections

Positive Index Mechanism (Style JF)

- Twelve positions
- Thirty (30) degree increments
- Conveniently located adjustable stops

Spring Return Index (Style JFM)

- Return positioning from both left and right

Qualified Product Listed (QPL) tested and approved per MIL-S-21604 for both styles:

- Circuit configuration
- Temperature rise
- Contact resistance
- Endurance
- Torque
- Seal
- Dielectric withstanding voltage
- Insulation
- Shock and Vibration
- Terminal strength
- Strength of mounting bushing
- Visual and mechanical

Panel-mounted Selector Switches

Type IC5846

Switch arrangement is basically a 4 pole, 2 position break before make (non-shorting) switch deck. Choose from 1 to 5 decks. As many as 20 circuits, if 5 decks used, can be transferred at one time.

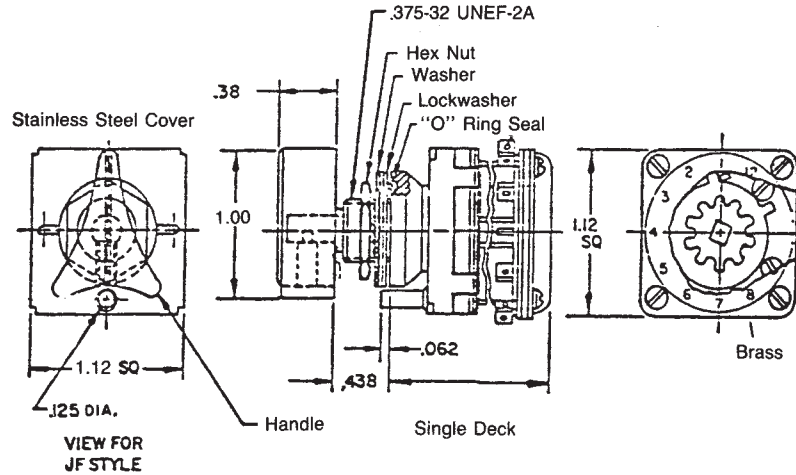

Rotor Contact Configuration

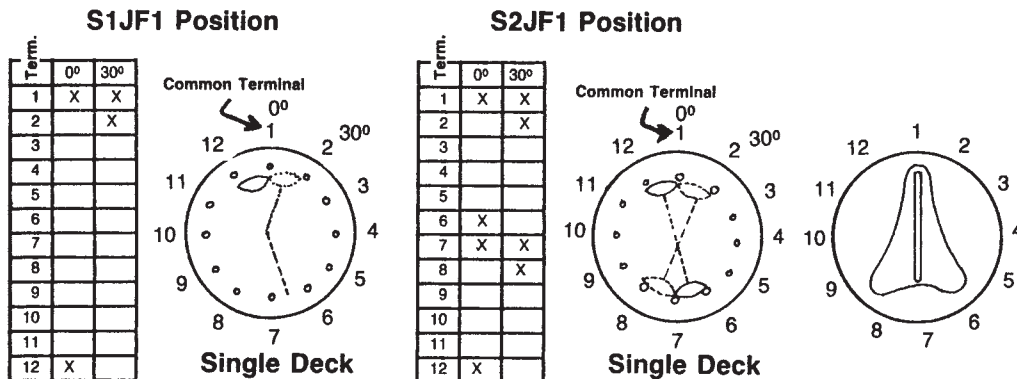

Nickel plated brass handle will be furnished unless otherwise specified. Use of small soldering iron to attach wires to terminals is highly recommended to prevent damage due to excessive wear and tension to the Kel-F sections. Rosin core solder is best to use when soldering the terminal leads.